

K. J. Somaiya College of Engineering, Mumbai-77
(Somaiya Vidyavihar University)

FY BTECH SEM I (Engineering Mechanics)

For a given coplanar concurrent force system find the resultant in magnitude and direction.

Q1

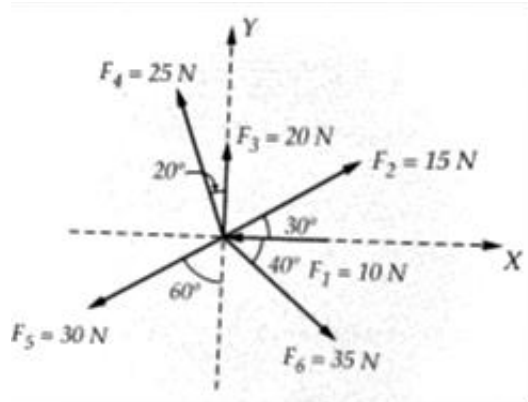

Q2

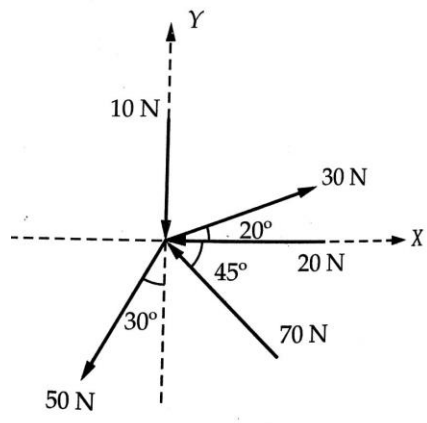

Q3

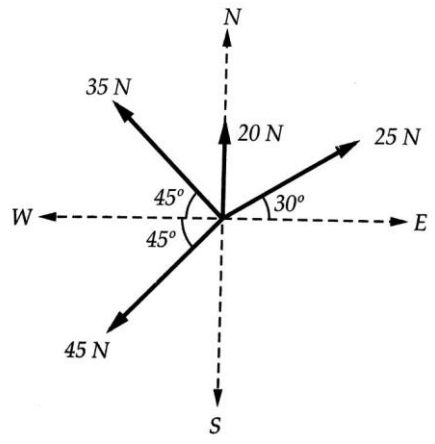

K. J. Somaiya College of Engineering, Mumbai-77
(Somaiya Vidyavihar University)

FY BTECH SEM I (Engineering Mechanics)

Q4 Find the equivalent force couple system for the forces shown below about point A.

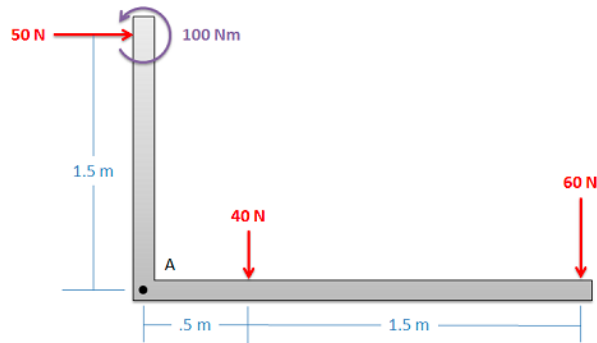

Q5. For a given force system find the resultant in magnitude and direction. Also find the equivalent resultant force and couple moment acting at A. (Forces are in KN and distance in m)

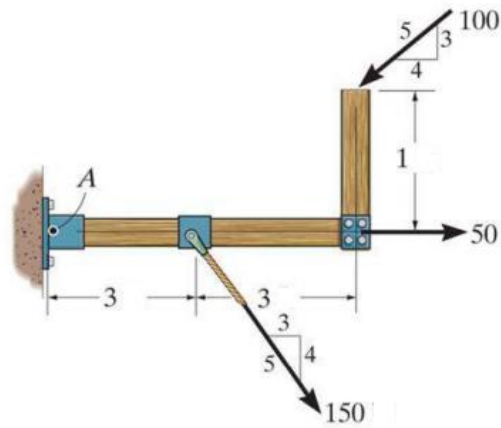

Q6 Determine resultant of given force system in magnitude and direction and locate it with respect to point 'A' Also find x and y intercept of resultant

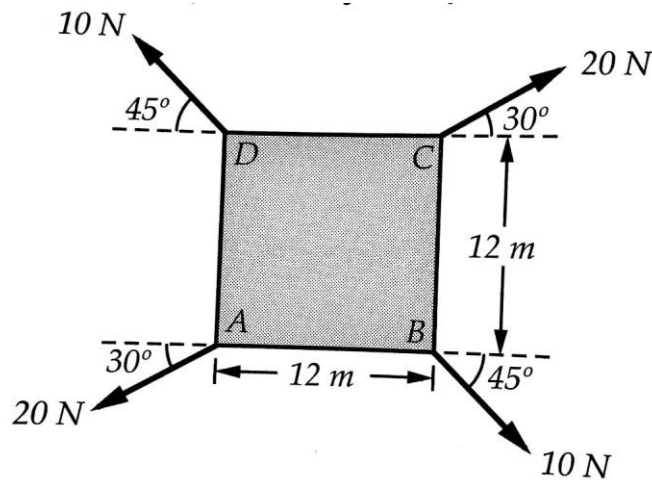

K. J. Somaiya College of Engineering, Mumbai-77
(Somaiya Vidyavihar University)

FY BTECH SEM I (Engineering Mechanics)

Q7 Determine resultant of given force system in magnitude and direction and locate it with respect to point 'O' Also find x and y intercept of resultant

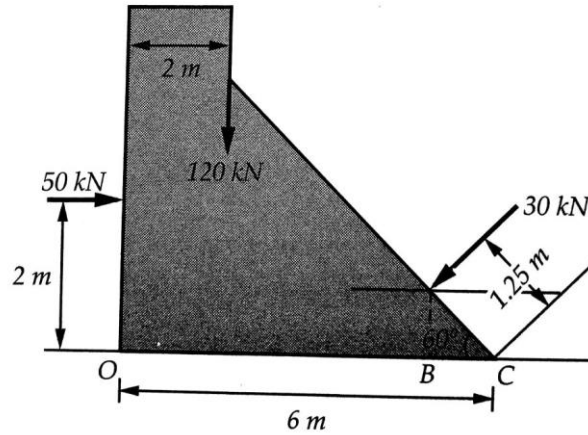

Q8 Replace the given force system by two parallel forces at B & D.

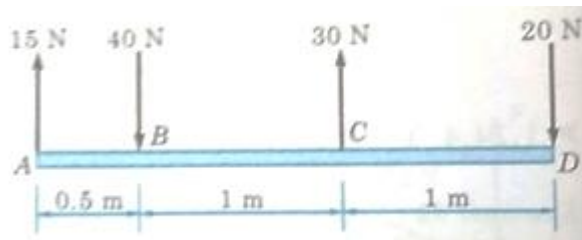

Q9 Find the resultant and locate with respect to A

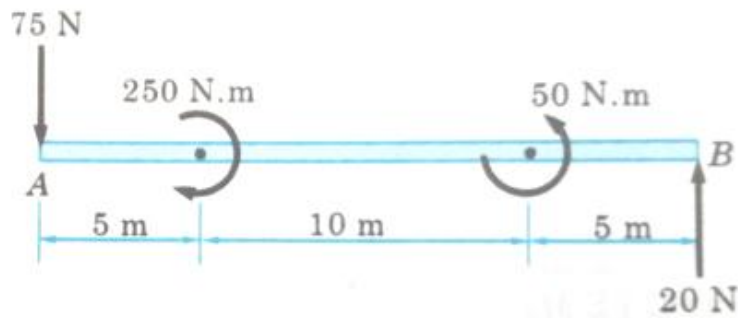

Q10 Find the resultant of given parallel force system

